



VHF - FM

high power

Version
02.00March
2006

Family of VHF FM Transmitters R&S®NR 8200

Air-cooled transmitters for 2.5 kW to 30 kW

- ◆ Powerful FM transmitters of solid-state design with excellent specifications
- ◆ New digital Exciter R&S®SU 800 with AES/EBU interface in one height unit
- ◆ Compact models featuring max. 1000 mm rack depth and up to 15 kW output power in a 19" rack
- ◆ Latest MOSFET technology for power amplifiers
- ◆ Transmitter remote control and remote monitoring via SNMP and/or web interface
- ◆ Color display
- ◆ Multilingual menus
- ◆ All conventional air ducting configurations feasible
- ◆ Standby concepts: exciter standby, (n+1) standby, passive standby and active amplifier standby
- ◆ Exciter standby and active amplifier standby with integrated Control Unit R&S®NetCCU® 800
- ◆ Integrated lightning protection
- ◆ Frequency-response-compensated directional coupler
- ◆ Operation and control as with the other TV transmitters of the R&S®Nx 8000 family



ROHDE & SCHWARZ

At a glance

The new air-cooled R&S®NR 8200 FM transmitter generation covers a power range from 2.5 kW to 30 kW. The transmitters include the following components:

- ◆ Exciter R&S®SU 800
- ◆ Power Amplifier R&S®VU 825
- ◆ Transmitter rack with cooling system
- ◆ Power combiner
- ◆ Power distribution
- ◆ Control Unit R&S®NetCCU® 800

All transmitters feature outstanding technical parameters, an optimum cost/benefit ratio, plus maximum reliability and ease of servicing. They are equipped with the new digital state-of-the-art Exciter R&S®SU 800 with integrated AES/EBU interface.

The compact air-cooled models with max. 1000 mm rack depth provide an output power of up to 15 kW in a 19" rack.

The R&S®NetCCU® 800 transmitter control unit handles both internal and external communication and provides all control functions. The R&S®NetCCU® 800 clearly shows the current status of the transmitter system on a color display in different languages. All transmitter and amplifier parameters required for diagnostics can be retrieved locally or remotely via standard (IP) protocol and standard software (web browser, SNMP).

Conventional standby systems such as exciter standby, (n+1) standby, passive standby and active amplifier standby can be implemented. No additional control units are needed for exciter standby and active amplifier standby.

The transmitters comply with the R&TTE Directive 1999/5/EU and meet the standards EN 60215 for personal safety, EN 301489-1 and 301489-11 for EMC, as well as EN 302018-1 and EN 302018-2 for RF requirements.

Exciter R&S®SU 800

The synthesizer-based digital Exciter R&S®SU 800 generates a frequency-modulated RF signal in the range from 87.5 MHz to 108 MHz. The use of state-of-the-art circuitry allows the R&S®SU 800 to be accommodated in a housing of only one height unit.

Both analog AF signals and digital signals in line with bit-serial AES/EBU protocol can be processed. Left/right, MPX, RDS or SCA signals can be used as modulation signals. Eight preset channels are available, and the settings for the active channel can be saved power-failure-proof in each of them.

All parameters, such as transmission frequency, RF output power, operating and modulation mode, module parameters, interfaces or system control, can be menu-set via the R&S®NetCCU® 800.





Power Amplifier R&S® VU 825

An innovative amplifier controller is used, which is identical for all sound and TV transmitters of the R&S® Nx 8000 family. This controller not only monitors and evaluates protective functions (e.g. overtemperature switchoff, VSWR reduction, transistor failure detection), but also provides phase correction and control of the RF output power. Output power control prevents, for example, the amplifier from being overdriven in the event a transistor fails, thus ensuring a long life for the individual transistors. Each amplifier module is, therefore, self-monitoring and self-protective.

The measured values of the exciter, the status (e.g. operating hours, system events) and the modulation values (e.g. frequency deviation, AF level) are evaluated and displayed. An error table rounds out the monitoring functions.

The RF output power is set and regulated by adjusting the drain voltage of the amplifier output stages. The harmonics filter in the amplifier ensures a harmonics suppression of >85 dB.

The two exciter fans are exchangeable during operation, making the exciter easy to service. A GPS module for even higher frequency stability can be optionally installed.

Power Amplifier R&S® VU 825

Equipped with the latest MOSFET technology, the R&S® VU 825 power amplifier features excellent efficiency and compact design. Each RF amplifier has its own power supply.

The signal is boosted to a power of approx. 2.7 kW in the RF amplifier. The R&S® VU 825 is modular in design and contains four identical 700 W base modules that are driven by a 64 W preamplifier.

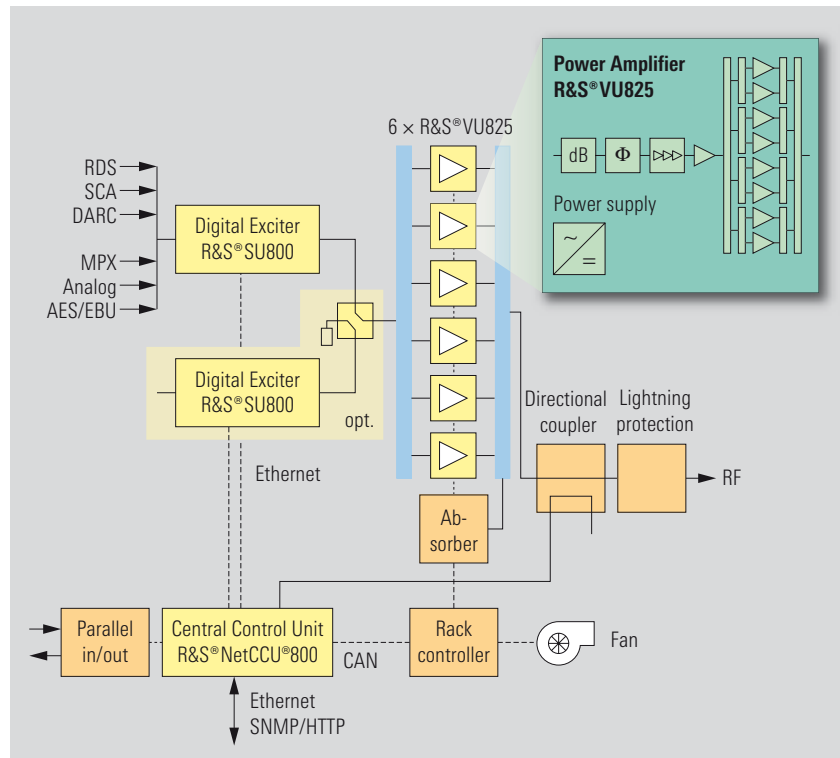

R&S® NR 8215 block diagram

An innovative CAN bus interface is used to transfer all relevant operating parameters and fault messages to the transmitter control unit. The amplifier modules can be easily replaced during operation.

If an amplifier has to be replaced, the transmitter does not have to be optimized or adjusted.

Control Unit R&S®NetCCU® 800

The R&S®NetCCU® 800 transmitter control unit handles both internal and external communication and provides all control functions. Only two height units suffice to implement the functions of a transmitter control unit plus an IP interface. The R&S®NetCCU® 800 clearly shows the current status of the transmitter system on a color display.

Communication with internal system components (amplifier, rack controller, other transmitter racks) is via the CAN bus. Communication with external components and with the exciter is via Ethernet.

All transmitter and/or amplifier parameters required for diagnostics can be retrieved locally as well as remotely from anywhere in the world via standard (IP) protocol and standard software (web browser/SNMP). This enables the transmitter status of unattended stations to be accurately evaluated, and any servicing that may be needed to be optimally prepared. Locally, this data can be retrieved via the IP interface of the R&S®NetCCU® 800.

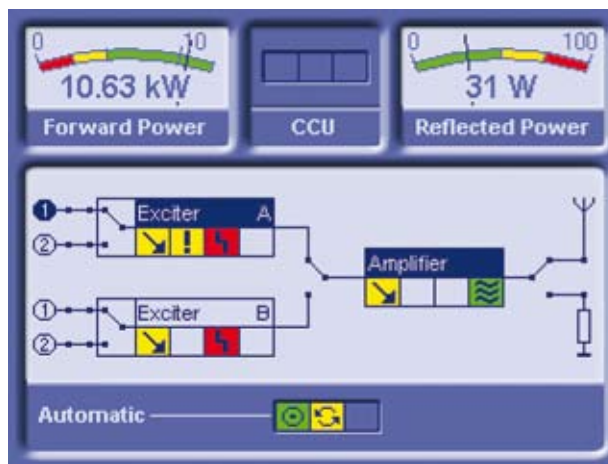

Main transmitter menu on the R&S®NetCCU® 800

Transmitter rack with integrated cooling

A 19" rack is used for all power classes. One rack accommodates up to six amplifier modules.

The transmitters are air-cooled by an internal or external fan. The internal fan is supplied with ambient air or via air ducts by a central ventilation system. The compact fan is very powerful and highly efficient.

Various air ducting configurations can be implemented, with cooling air intake from the top, bottom or rear of the transmitter rack, and exhaust air discharge toward the top or bottom. Each amplifier module contains an optimized, highly efficient heat sink. This in conjunction with the elaborate cooling concept ensures effective cooling with only small amounts of air.

An innovative, nearly wireless power distribution system eliminates wiring errors during assembly and servicing.

The frequency-response-compensated directional coupler integrated in the transmitter and built-in lightning protection round out the R&S®NR 8200 transmitter family.

Other products

- ◆ DAB VHF band III and L band transmitters
- ◆ Analog/digital VHF TV transmitters
- ◆ Analog/digital UHF TV transmitters
- ◆ Datacasting equipment
- ◆ DVB-H systems
- ◆ Broadcasting test and measurement equipment
- ◆ Complete transmitter systems, including container solutions

Specifications

Frequency range	87.5 MHz to 108 MHz		
Internal tuning	menu-controlled in 10 kHz steps		
External tuning	8 frequencies, selectable		
Frequency drift	<200 Hz/3 months		
Center frequency offset at frequency deviation ± 75 kHz	typ. 0 Hz		
Nominal frequency deviation	adjustable from ± 40 kHz to ± 150 kHz		
Deviation limiter	adjustable from ± 40 kHz to ± 150 kHz		
Maximum frequency deviation	± 150 kHz		
Class of emission	F3E, stereo and mono		
Stereo emissions	in line with ITU-R BS.450-3		
RF output			
Nominal impedance	50 Ω		
Connector	see table "Model-specific data"		
Audio input			
Connector	XLR on transmitter top		
	L and R mode	multiplex mode	AES/EBU mode
Input impedance	600 Ω or >2 k Ω , balanced/unbalanced		110 Ω , balanced
AF input level for nominal deviation	-6 dBu to +12 dBu	+5 dBu to +7 dBu	200 mV to 10 V (pp)
Remote interfaces (control interfaces, remote-control interfaces)			
BITBUS	optional		
Parallel remote-control interface	optional		
TCP/IP	HTTP, SNMP		
Auxiliary frequency			
Pilot tone frequency	19 kHz		
Amplitude	1 V (pp) + 0.1 V and 1 k Ω ; unbalanced		
Pilot tone deviation	0 Hz to 15 kHz, adjustable in 100 Hz steps		
Output	BNC		
General data			
AC supply voltage	380 V or 400 V or 415 V, 3 phases + neutral wire ¹⁾		
AC supply frequency	50 Hz or 60 Hz ¹⁾		
Permissible voltage variation	$\pm 15\%$		
Power ratio	>0.9		
Cooling	air cooling by internal fan (air ducts or ambient air) or external fan		
Operating temperature range	+1 °C to +45 °C, upper limit decreases by 5 °C for each 1000 m of elevation above mean sea level		
Storage temperature range	-40 °C to +70 °C		
Permissible relative humidity	<95 % at 26 °C		
Permissible external electric field strength	<10 V/m		
Maximum installation height	3000 m above mean sea level		

¹⁾ To be specified when placing the order.

Model-specific data

	R&S® NR 8202	R&S® NR 8205	R&S® NR 8207	R&S® NR 8210	R&S® NR 8212	R&S® NR 8215	R&S® NR 8220	R&S® NR 8230
Nominal output power	2.5 kW	5 kW	7.5 kW	10 kW	12.5 kW	15 kW	20 kW	30 kW
Number of amplifiers	1	2	3	4	5	6	8	12
Connector	1 5/8" EIA	1 5/8" EIA	1 5/8" EIA	1 5/8" EIA	1 5/8" EIA	3 1/8" EIA	3 1/8" EIA	3 1/8" EIA
Dimensions (W × H × D)								
Version with internal fan, air ducts	600 mm × 2000 mm × 800 mm			600 mm × 2000 mm × 1000 mm			1200 mm × 2000 mm × 1000 mm	
Version with internal fan, ambient air	600 mm × 2000 mm × 950 mm						1200 mm × 2000 mm × 950 mm	
Version with external fan	600 mm × 2000 mm × 800 mm						1200 mm × 2000 mm × 800 mm	
Volume flow rate of internal fan at 1000 hPa barometric pressure (frequency 50 Hz)								
Version with air ducts	20 m³/min		25 m³/min		35 m³/min		70 m³/min	
Version with ambient air	20 m³/min		25 m³/min		35 m³/min		50 m³/min	70 m³/min
Internal fan motor power (frequency 50 Hz)								
Version with air ducts	1.1 kW		1.5 kW		2.2 kW		4.4 kW	
Version with ambient air	1.1 kW		1.5 kW		2.2 kW		3.0 kW	4.4 kW



More information at
www.rohde-schwarz.com
 (search term: NR8200)



www.rohde-schwarz.com

Europe: +49 1805 12 4242, customersupport@rohde-schwarz.com
 USA and Canada: 1-888-837-8772, customer.support@rsa.rohde-schwarz.com
 Asia: +65 65 130488, customersupport.asia@rohde-schwarz.com